



CE

www.kdhoist.com

KUKDONG, A Reader of Electric Hoist

# HOIST



극동호이스트(주)  
KUKDONG HOIST CO., LTD.

# Overview

## 극동호이스트(주)

는 산업물류의 운반과 생산의 효율화를 통하여 세계 인류공영에 이바지 하고자 하역운반기계의 핵심이 되는 전동 체인 호이스트 및 전동 와이어 호이스트, 체인 블럭, 크레인 전문업체로 1983년에 설립되었습니다.

설립 후 저희 회사는 축적된 기술과 품질 향상으로 꾸준히 성장하여 현재는 동 분야의 한국 최대, 최고 수준의 하역운반기계 전문업체로 발전하였습니다.

이는 저희 회사가 1988년부터 한국 정부인가에 의한 극동운반기술연구소를 설립,운용하면서 과감한 R&D 투자로 제품개선과 신기술, 신제품 개발을 주도한 결과이며, 한국정부 주관의 신기술 인증인 NT(New Technology), 유럽연합(EC)의 제품신뢰성 인증인 CE, 한국정부 인증의 산업안전규격 S마크의 획득과 국제품질 표준화 규격인ISO 9001인증으로 증명되고 있습니다.

아울러 극동호이스트(주)는 단순히 회사이윤의 증대 보다는 고객이 만족할만한 제품을 최대한 경제적인 가격으로 보답하는 것을 경영이념으로 하고 있습니다.

이는 회사 창립 이래 지금까지 단일 가격 정책을 고수하고 있는 것과 사용의 간편성과 편리성을 최대한 고려하면서도 원가절감을 이룬

세계시장 전략형 KD-1, KD-2 Type 형 당사 신제품 전동 체인 호이스트로 확인하실 수 있습니다.

## 극동호이스트(주)의 경영방침은 기술경영, 일등제품입니다.

앞으로도 우리 회사는 세계 유수의 하역운반기계 업체와 당당히 기술력으로 맞서 세계 속의 극동 호이스트로 자리 메김 할 것이며 21C 미래형 사업영역을 구축하는 산업 운반기술을 선도하는 기업으로 고객의 요구에 부응하는 초일류 기업이 될 것을 약속 드립니다.



# History

## 1980'

- 1983. 12. 15 (주)극동기연 설립
- 1984. 08. 10 일본 NITCHE 환와 기술제휴
- 1985. 12. 24 중소기업 근대화실천승인업체 선정 (중소기업진흥공단)
- 1987. 11. 30 대통령 산업포장 수상 (전동호이스트 국산화 개발)
- 1988. 04. 06 극동운반기술연구소 설립 (과학기술체)

## 1990'

- 1998. 11. 04 CE 마크 획득 (독일 TÜV Rheinland)
- 1998. 11. 07 S 마크 획득 (산업안전연구원)
- 1999. 02. 11 수출지원 대상업체로 지정 (경기중소기업 수출지원센터장)
- 1999. 03. 22 중소기업 수출기업화사업 대상업체로 선정 (경기도)
- 1999. 09. 17 UDT 안전인증 마크 획득 (POLAND)

## 1990'

- 1990. 12. 29 중소기업 기술 선진화 업체 선정 (상공부)
- 1991. 11. 08 병역 특례업체로 선정
- 1994. 11. 01 NT(신기술)마크 획득 (산업자원부)
- 1995. 05. 10 제3회 신학연 대상수상 (신학연 협동연구소)
- 1997. 09. 11 ISO 9002 인증획득 (SMICO)

## 2000'

- 2003. 10. 01 ISO 9001인증획득 (OEC-KOREA)
- 2005. 03. 04 극동호이스트(주)로 상호변경
- 2007. 05. 22 Global Standard 경영대상 (기술경영 부문) 수상

## Hoist Classification

### Short Time Rating

Rate of loading	Avg. daily operating time (hr)	Max. 0.25	0.25 < X ≤ 0.5	0.5 < X ≤ 1	1 < X ≤ 2	2 < X ≤ 4	4 < X ≤ 8	8 < X ≤ 16	Min. 16
	Total operating time (hr)	Max. 400	400 < X ≤ 800	800 < X ≤ 1600	1600 < X ≤ 3200	3200 < X ≤ 6300	6300 < X ≤ 12500	12500 < X ≤ 25000	Min. 25000
Light	When normally working with approx. 1/3 of W.L.L. and rarely with W.L.L.	-	M1	M2	M3	M4	M5	M6	M7
Medium	When normally working with approx. 1/3 to 2/3 of W.L.L. and sometimes with W.L.L.	M1	M2	M3	M4	M5	M6	M7	M8
Heavy	When normally working with approx. 2/3 of W.L.L. and often with W.L.L.	M2	M3	M4	M5	M6	M7	M8	-
Very heavy	When normally working with W.L.L. or near W.L.L.	M3	M4	M5	M6	M7	M8	-	-

\* Total operating time applies to gears, and other mechanical parts; consumable parts are not taken into calculation.

● The grade symbols are identical to those of ISO4301. (Cranes and lifting appliance-Classification)

## Lifting Motor Rating

### Short Time Rating

This rating indicates how long the hoist can be operated continuously on the below cycle, assuming continued operation for a short time span.

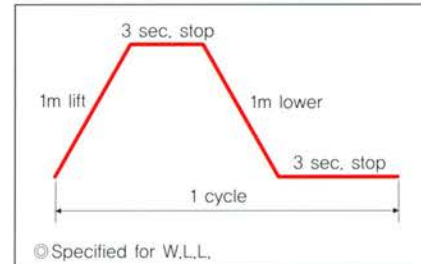

- Single Speed : 30min
- Dual Speed : 5/15min

### ASME HST

Hoist duty class	Typical areas of application	Operation time ratings at K= 0.65			
		Uniformly distributed work periods		Infrequent work periods	
		Max. on time, min/hr	Max. No. starts/hr	Max. on time from cold start, min	Max. No. of starts
H2	Light machine shop fabricating, service, and maintenance; loads and utilization randomly distributed; rated loads infrequently handled	7.6 (12.5%)	75	15	100
H3	General machine shop fabricating, assembly, storage, and warehousing; loads and utilization randomly distributed	15 (25%)	150	30	200
H4	High volume handling in steel warehouses, machine shops, fabricating plants and mills, and foundries; manual or automatic cycling operations in heat treating and plating; loads at or near rated load frequently handled	30 (50%)	300	30	300

● The grade symbols are identical to those of ASME HST-1M. (Performance standard for Electric Chain Hoist)

### Intermittent Rating(PercentED) Max. Number of Starts Per Hour

This rating indicates the ED percent (ratio of motor ON-to-OFF time) and Max. number of starts per hour (how many times the motor is started up in one hour) for a hoist operated continuously on the below cycle, assuming continued operation or repeated starting over a long time span.

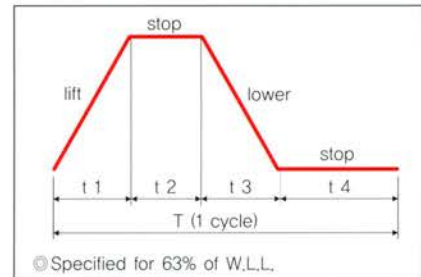

In case of single speed :

$$\%ED = \frac{\text{Motor ON time (t1+t3)}}{\text{1cycle (T)}} \times 100$$

$$T = 1 \text{ cycle (t1+t2+t3+t4)}$$

(Within 10 minutes)

%ED and Max. number of starts per hour

- Single Speed : 25%ED, 360 starts/hr
- Dual Speed : 20%ED, 120/240 starts/hr

### FEM

#### Relation between ISO-and FEM-Denominations

1 Dm	1 Cm	1 Bm	1 Am	2 m	3 m	4 m	5 m	Class of operation time	Average operating time per day (in hours)	Calculated total operating time(in hours)				
M 1	M 2	M 3	M 4	M 5	M 6	M 7	M 8							
Load spectrum	Cubic mean value	Class of operation time								V0.06 T0	≤0.12	200		
		V0.06 T0	V0.02 T1	V0.25 T2	V0.5 T3	V1 T4	V2 T5	V3 T6	V4 T7				V5 T8	
		Average operating time per day in hours								V0.12 T1	≤0.25	400		
		≤0.12	≤0.25	≤0.5	≤1	≤2	≤4	≤8	≤16				≤16	
1 L1	K ≤ 0.50	-	-	1Dm	1Cm	1Bm	1Am	2m	3m	4m	V0.25 T2	≤0.5	800	
2 L2	0.50 < K ≤ 0.63	-	-	1Dm	1Cm	1Bm	1Am	2m	3m	4m	5m	V0.5 T3	≤1	1,600
3 L3	0.63 < K ≤ 0.80	1Dm	1Cm	1Bm	1Am	2m	3m	4m	5m	-	V1 T4	≤2	3,200	
4 L4	0.80 < K ≤ 1.00	1Cm	1Bm	1Am	2m	3m	4m	5m	-	-	V2 T5	≤4	6,300	
											V3 T6	≤8	12,500	
											V4 T7	≤16	25,000	
											V5 T8	>16	50,000	

● The grade symbols are identical to those of FEM 9,511. (Rules for Design of Serial Lifting Equipment : Classification of Mechanisms)

# KD-1 type

Available from 0.49Ton to 2Ton capacity



## KD-1 type

- Hoist classification : FEM(1Bm) / ISO(M3)
- Motor & brake class : "F" class
- Ambient temperature : -20°C ~ +40°C
- Intermittent Rating(%ED) :  
single speed(25%ED) / dual speed(20%ED)

- High class Slip clutch system
- DC brake system
- Emergency stop
- Powerful motor
- KD manufactured load chain

### I STANDARD SPECIFICATION

Model	Capacity (ton)	Lift (m)	Duty rating (min)		Lifting Speed (m/min)				Traversing Speed (m/min)		Load Chain Dia. (mm)	No. of Falls of Load Chain	Test Load (kg)
			Single	Dual	Single		Dual		50Hz	60Hz			
					50Hz	60Hz	50Hz	60Hz					
KD-1	0.49	4	30	5/15	6.7	8	6.7/1.7	8.0/2.0	-	-	Φ7.1	1	613
	0.5	4	30	5/15	6.7	8	6.7/1.7	8.0/2.0	-	-	Φ7.1	1	625
	1	4	30	5/15	6.7	8	6.7/1.7	8.0/2.0	-	-	Φ7.1	1	1,250
	2	4	30	5/15	3.4	4	3.4/0.9	4.0/1.0	-	-	Φ7.1	2	2,500
KD-1M	0.49	4	30	5/15	6.7	8	6.7/1.7	8.0/2.0	10, 20	12, 24	Φ7.1	1	613
	0.5	4	30	5/15	6.7	8	6.7/1.7	8.0/2.0	10, 20	12, 24	Φ7.1	1	625
	1	4	30	5/15	6.7	8	6.7/1.7	8.0/2.0	10, 20	12, 24	Φ7.1	1	1,250
	2	4	30	5/15	3.4	4	3.4/0.9	4.0/1.0	10, 20	12, 24	Φ7.1	2	2,500

Capacity (ton)	Output (kw)		Traversing (kw)	Net weight		Extra weight per 1m lift (kg)	
	Single	Dual		KD-1	KD-1M	KD-1	KD-1M
0.49	0.8	0.8/0.2	0.4	55 (57)	95 (97)	1.1	1.1
0.5	0.8	0.8/0.2	0.4	55 (57)	95 (97)	1.1	1.1
1	1.5	1.5/0.38	0.4	59 (61)	100 (102)	1.1	1.1
2	1.5	1.5/0.38	0.4	75 (77)	115 (117)	2.1	2.1

### I DIMENSION

Model	Capacity (ton)	Dimension (mm)											Std. I-Beam Width (mm)	Min. Radius of Curve (mm)
		A	B	C	D	E	F	H	S	W	P	G		
KD-1	0.49	258	265 (315)	132	132	-	29	-	-	40	663	450	-	-
	0.5	258	265 (315)	132	132	-	29	-	-	40	663	450	-	-
	1	258	308 (335)	132	132	-	29	-	-	40	663	450	-	-
	2	258	308 (335)	97	167	-	34	-	-	50	683	640	-	-
KD-1M	0.49	258	265 (315)	75	338	218	29	121	230	40	663	435	75,100,125	1,000
	0.5	258	265 (315)	75	338	218	29	121	230	40	663	435	75,100,125	1,000
	1	258	308 (335)	100	350	230	29	121	230	40	663	435	75,100,125	1,000
	2	258	308 (335)	125	363	243	34	123	296	50	667	670	100,125,150	1,500

( ) Dual speed Dimension, Specification

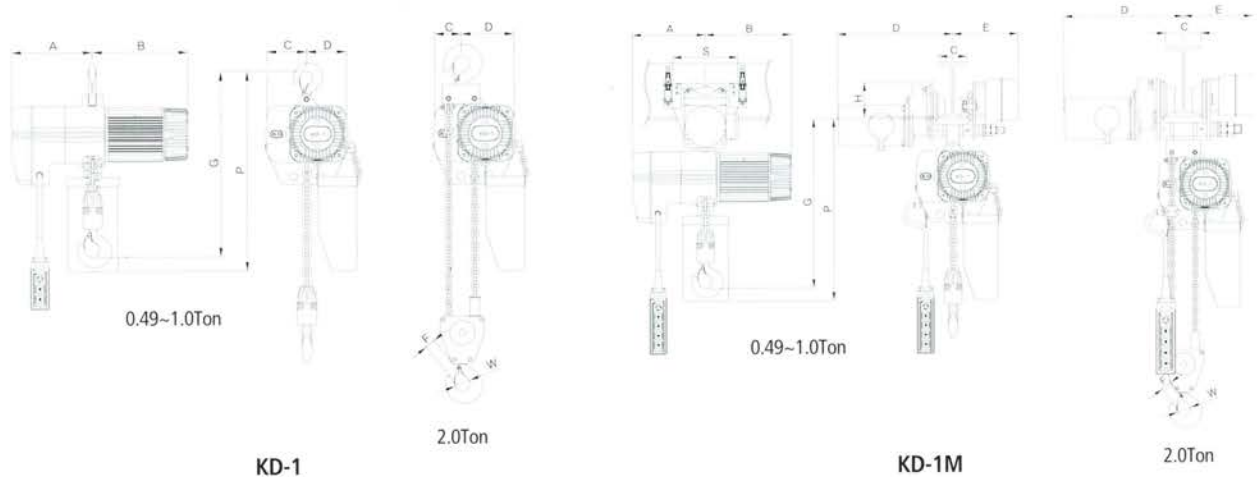

\* The design, material and specification are subject to change for improvement without notice.  
 \* A special specification is available upon request.  
 \* 국동코이스트(주) 제품의 규격은 품질개선을 위하여 예고없이 변경될 수 있으므로 제품 구입시 문의하십시오.

\* F 치수는 안전고리 제외한 치수임

# KD-2 type

Available from 2Ton to 5Ton capacity



## KD-2 type

- Hoist classification : FEM(1Bm) / ISO(M3)
- Motor & brake class : "F" class
- Ambient temperature : -20°C ~ +40°C
- Intermittent Rating(%ED) :  
single speed(25%ED) / dual speed(20%ED)
- Mechanical brake system
- Upper/lower limit switch
- DC brake system
- Emergency stop
- Powerful motor
- KD manufactured load chain

### I STANDARD SPECIFICATION

Model	Capacity (ton)	Lift (m)	Duty rating (min)		Lifting Speed (m/min)				Traversing Speed (m/min)		Load Chain Dia. (mm)	No. of Falls of Load Chain	Test Load (kg)
			Single	Dual	Single		Dual		50Hz	60Hz			
					50Hz	60Hz	50Hz	60Hz					
KD-2	2	4	30	5/15	6.8	8.2	6.8/1.7	8.2/2.0	-	-	φ11.2	1	2,500
	2.8	4	30	5/15	4.3	5.2	4.3/1.1	5.2/1.3	-	-	φ9.5	2	3,500
	3	4	30	5/15	4.3	5.2	4.3/1.1	5.2/1.3	-	-	φ9.5	2	3,750
	5	4	30	5/15	3.0	3.6	3.0/0.8	3.6/0.9	-	-	φ11.2	2	6,250
KD-2M	2	4	30	5/15	6.8	8.2	6.8/1.7	8.2/2.0	10	12	φ11.2	1	2,500
	2.8	4	30	5/15	4.3	5.2	4.3/1.1	5.2/1.3	10	12	φ9.5	2	3,500
	3	4	30	5/15	4.3	5.2	4.3/1.1	5.2/1.3	10	12	φ9.5	2	3,750
	5	4	30	5/15	3.0	3.6	3.0/0.8	3.6/0.9	10	12	φ11.2	2	6,250

Capacity (ton)	Output (kw)		Traversing (kw)	Net weight		Extra weight per 1m lift (kg)	
	Single	Dual		KD-2	KD-2M	KD-2	KD-2M
2	3.3	3.3/0.825	0.4	137 (147)	177 (187)	2.7	2.7
2.8	3.3	3.3/0.825	0.4	151 (161)	208 (218)	4.0	4.0
3	3.3	3.3/0.825	0.4	151 (161)	208 (218)	4.0	4.0
5	3.3	3.3/0.825	0.4	160 (170)	243 (253)	5.3	5.3

### I DIMENSION

Model	Capacity (ton)	Dimension (mm)											Std. I-Beam Width (mm)	Min. Radius of Curve (mm)
		A	B	C	D	E	F	H	S	W	P	G		
KD-2	2	307	355 (392)	168	168	-	34	-	-	50	805	790	-	-
	2.8	307	355 (392)	113	223	-	41	-	-	60	895	970	-	-
	3	307	355 (392)	113	223	-	41	-	-	60	895	970	-	-
	5	307	355 (392)	113	223	-	48	-	-	67	970	1,095	-	-
KD-2M	2	307	355 (392)	125	245	418	34	123	296	60	770	755	100, 125, 150	1,500
	2.8	307	355 (392)	125	254	357	41	136	337	60	900	925	100, 125, 150	1,500
	3	307	355 (392)	125	254	357	41	136	337	60	900	925	100, 125, 150	1,500
	5	307	355 (392)	150	270	443	48	158	384	67	950	1,054	125, 150, 175	2,000

( ) Dual speed Dimension, Specification

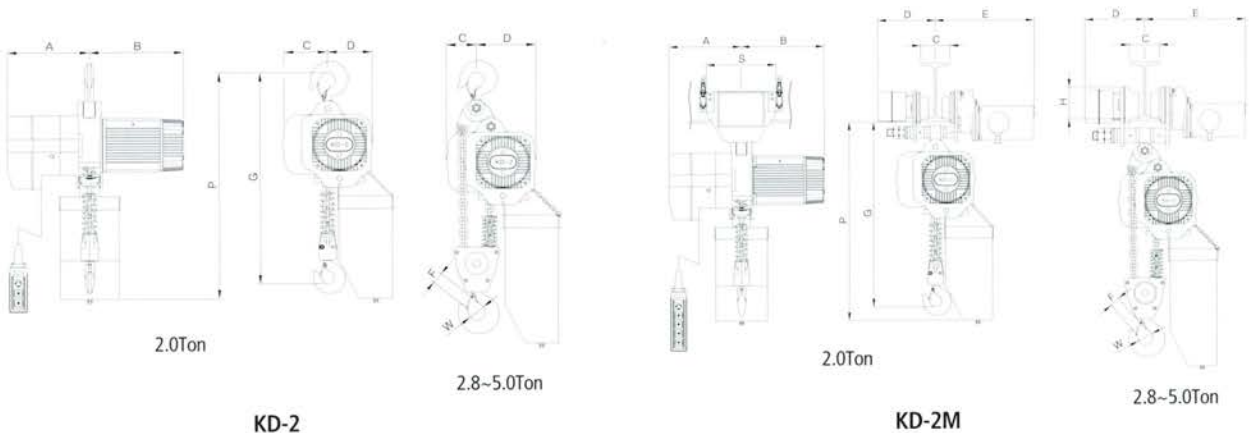

• The design, material and specification are subject to change for improvement without notice.  
 • A special specification is available upon request.  
 • 국동호미스트(주) 제품의 규격은 품질개선을 위하여 예고없이 변경될 수 있으므로 제품 구입시 문의바랍니다.

※ F 치수는 안전고리 제외된 치수임

# KE-90(EC-3M) type

Available from 0.49Ton to 3Ton capacity



## KE-90 type

- Hoist classification : FEM(1Bm) / ISO(M3)
- Motor & brake class : "F" class
- Ambient temperature : -20°C ~ +40°C
- Intermittent Rating(%ED) :  
single speed(25%ED) / dual speed(20%ED)
- Solenoid brake system
- 3-step reduction gear
- Upper/lower limit switch
- Emergency stop
- KD manufactured load chain



### I STANDARD SPECIFICATION

Model	Capacity (ton)	Lift (m)	Duty rating (min)		Lifting Speed (m/min)				Traversing Speed (m/min)		Load Chain Dia. (mm)	No. of Falls of Load Chain	Test Load (kg)
			Single	Dual	Single		Dual		50Hz	60Hz			
					50Hz	60Hz	50Hz	60Hz					
KE-90 (EC-3M)	0.49	4	30	5/15	8.3	10	8.3/2	10/2.5	-	-	φ6.3	1	613
	0.5	4	30	5/15	8.3	10	8.3/2	10/2.5	-	-	φ6.3	1	625
	1	4	30	5/15	5.4	6.4	5.4/1.4	6.4/1.6	-	-	φ7.1	1	1,250
	2	4	30	5/15	2.7	3.2	2.7/0.7	3.2/0.8	-	-	φ7.1	2	2,500
	2.8	4	30	5/15	1.8	2.1	1.8/0.5	2.1/0.5	-	-	φ7.1	3	3,500
KE-90M (EMT-EC-3M)	0.49	4	30	5/15	8.3	10	8.3/2	10/2.5	10, 20	12, 24	φ6.3	1	613
	0.5	4	30	5/15	8.3	10	8.3/2	10/2.5	10, 20	12, 24	φ6.3	1	625
	1	4	30	5/15	5.4	6.4	5.4/1.4	6.4/1.6	10, 20	12, 24	φ7.1	1	1,250
	2	4	30	5/15	2.7	3.2	2.7/0.7	3.2/0.8	10, 20	12, 24	φ7.1	2	2,500
	2.8	4	30	5/15	1.8	2.1	1.8/0.5	2.1/0.5	10, 20	12, 24	φ7.1	3	3,500
3	4	30	5/15	1.8	2.1	1.8/0.5	2.0/0.5	10, 20	12, 24	φ7.1	3	3,750	

Capacity (ton)	Output (kw)		Traversing (kw)	Net weight		Extra weight per 1m lift (kg)	
	Single	Dual		KE-90 (EC-3M)	KE-90M (EMT-EC-3M)	KE-90 (EC-3M)	KE-90M (EMT-EC-3M)
0.49	1.1	1.1/0.28	0.2	42 (46)	73 (78)	0.9	0.9
0.5	1.1	1.1/0.28	0.2	42 (46)	73 (78)	0.9	0.9
1	1.3	1.3/0.32	0.2	57 (61)	85 (88)	1.1	1.1
2	1.3	1.3/0.32	0.4	66 (70)	115 (118)	2.1	2.1
2.8	1.3	1.3/0.32	0.4	80 (84)	150 (153)	3.2	3.2
3	1.3	1.3/0.32	0.4	80 (84)	150 (153)	3.2	3.2

### I DIMENSION

Model	Capacity (ton)	Dimension (mm)											Std.I-Beam Width (mm)	Min. Radius of Curve (mm)
		A	B	C	D	E	F	H	S	W	P	G		
KE-90 (EC-3M)	0.49	236	230 (260)	133	133	-	29	-	-	40	590	590	-	-
	0.5	236	230 (260)	133	133	-	29	-	-	40	590	590	-	-
	1	250	240 (270)	155	155	-	29	-	-	40	688	688	-	-
	2	250	240 (270)	108	190	-	34	-	-	50	650	650	-	-
	2.8	250	240 (270)	110	275	-	41	-	-	60	750	750	-	-
KE-90M (EMT-EC-3M)	0.49	236	230 (260)	75	350	235	29	110	240	40	642	570	75, 100, 125	1,000
	0.5	236	230 (260)	75	350	235	29	110	240	40	642	570	75, 100, 125	1,000
	1	250	240 (270)	100	350	235	29	110	240	40	655	585	75, 100, 125	1,000
	2	250	240 (270)	125	354	239	34	125	300	50	690	665	100, 125, 150	1,500
	2.8	250	240 (270)	125	363	248	41	138	350	60	750	770	100, 125, 150	1,500
3	250	240 (270)	125	363	248	41	138	350	60	750	770	100, 125, 150	1,500	

( ) Dual speed Dimension, Specification

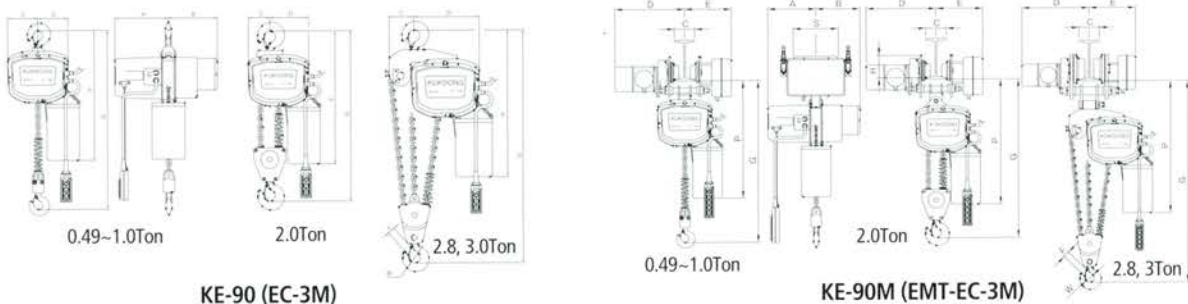

• The design, material and specification are subject to change for improvement without notice.  
 • A special specification is available upon request.  
 • 곡동호이스트(주) 제품의 규격은 품질개선을 위하여 예고없이 변경될 수 있으므로 제품 구입시 문의바랍니다.

※ F 치수는 안전고리 제한된 치수임

# MN type

Available from 125kg to 500kg capacity



## MN type

- Hoist classification : FEM(1Bm)/ISO(M3)
- Motor class : "B" class
- Ambient temperature : -20°C ~ +40°C
- Intermittent Rating(%ED) : 30%ED

- BLDC motor(750w)
- Mechanical brake combined with slip clutch system
- Variable speed control (2.0~14.0m/min)
- Variable & useful service
- Easy handle & Easy installation & Easy carry
- Super light weight(14kg)
- Single phase hoist

## I STANDARD SPECIFICATION

Model	Capacity (kg)	Lift (m)	Duty rating (min)	Lifting Speed (m/min)				Traversing Speed (m/min)		Load Chain Dia. (mm)	No. of Falls of Load Chain	Test Load (kg)
				Single		Variable		50Hz	60Hz			
				50Hz	60Hz	50Hz	60Hz					
MN	125	4	30	10		<15	-	-	φ4	1	156	
	250	4	30	10		<15	-	-	φ4	1	313	
	500	4	30	5		<15	-	-	φ4	2	625	
MNP	125	4	30	10		<15	-	-	φ4	1	156	
	250	4	30	10		<15	-	-	φ4	1	313	
	500	4	30	5		<15	-	-	φ4	2	625	

Capacity (kg)	Output (kw)		Traversing (kw)	Net weight (kg)		Extra weight per 1m lift (kg)	
	Single	Dual		MN	MNP	MN	MNP
125	0.75		-	19	26	0.4	0.4
250	0.75		-	19	26	0.4	0.4
500	0.75		-	25	32	0.8	0.8

## I DIMENSION

Model	Capacity (kg)	Dimension (mm)							Std.I-Beam Width (mm)	Min. Radius of Curve (mm)
		A	B	C	D	G	P	S		
MN	125	166	143	130	126	340	340	79	-	-
	250	166	143	130	126	340	340	79	-	-
	500	166	143	130	126	400	400	79	-	-
MNP	125	166	143	130	309	450	550	212	64~140	900
	250	166	143	130	309	450	550	212	64~140	900
	500	166	143	130	309	525	435	212	64~140	900

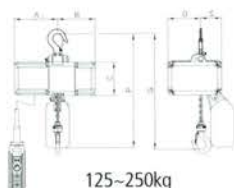

125~250kg

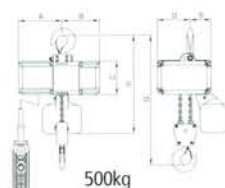

500kg

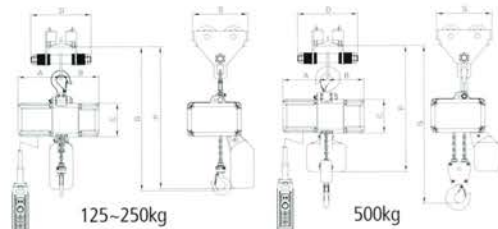

125~250kg

500kg

MN-125/MN-250/MN-500

MNP-125/MNP-250/MNP-500

# CHAIN BUCKET SIZE

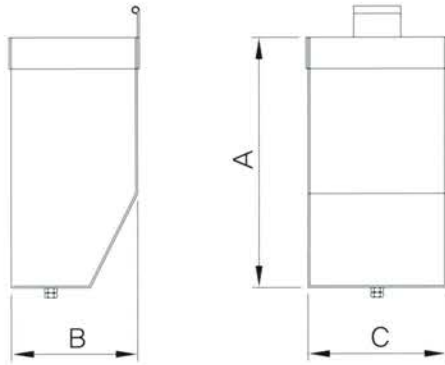

Size	Dimension (mm)		
	A	B	C
S-0	400	200	220
S-1	500	200	300
S-2	600	200	300
S-3	700	220	340
S-4	800	220	340
S-5	900	220	340
S-6	1050	220	420
S-7	1150	220	420

P : PLASTIC BUCKET (STANDARD LIFT)

## I KD-1, KD-2

Lift	Model Ton	KD-1			KD-2			
		0.5	1.0	2.0	2.0	2.8	3.0	5.0
1								
2								
3				P		S-0	S-0	S-0
4		P	P		S-0			
5								
6				S-0				S-1
7						S-1	S-1	
8								
9								S-2
10								
11				S-1		S-2	S-2	
12					S-1			
13		S-0	S-0					S-3
14						S-3	S-3	
15				S-2				
16								S-4
17								
18					S-2	S-4	S-4	
19								S-5
20		S-1	S-1	S-3		S-5	S-5	
21								
22								
23								
24								
25				S-4				S-6
26					S-3	S-6	S-6	
27								
28		S-2	S-2					
29				S-5				
30								S-7

## I HOOK

Model	Standard (Ton)	Normal dimension(A) (mm)	Using limit(A) (mm)
KD-1	0.5, 1.0, 2.0	30.5	36.0
	2(S)	33.5	37.0
KD-2	2.8(D), 3.0(D)	39.9	48.1
	5(D)	48.3	57.8
	7.5, 10	70.5	85.5

## I Load chain

Model	Standard (Ton)	Chain diameter $\phi d$ (mm)	Standard dimension Pitch (mm)	Using limit 11 links (mm)
KD-1	0.5, 1.0, 2.0	7.1	2.12	251.4
	2.8(D), 3.0(D)	9.5	28.6	337.6
KD-2	2(S), 5(D)	11.2	34.3	403.7
	7.5, 10	11.2	34.3	403.7

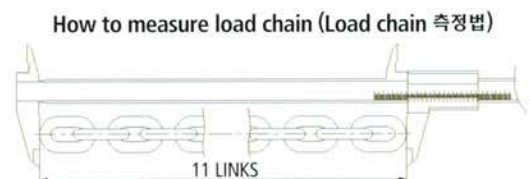
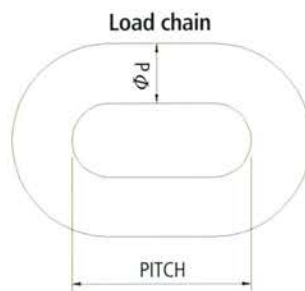
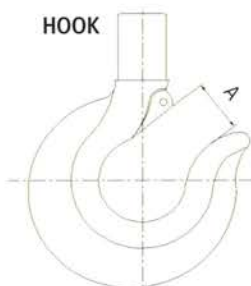

\* The design, material and specification are subject to change for improvement without notice.  
 \* A special specification is available upon request.  
 \* 곡동로이스트(주) 제품의 규격은 품질개선을 위하여 예고없이 변경될 수 있으므로 제품 구입시 문의바랍니다.

# LARGE CAPACITY type

Available from 7.5Ton to 30Ton capacity



## LARGE CAPACITY type

- Hoist classification : FEM(1Bm) / ISO(M3)
- Motor & brake class : "F" class
- Ambient temperature : -20°C ~ +40°C
- Intermittent Rating(%ED) :  
single speed(25%ED) / dual speed(20%ED)

- Stable and balanced two-body design
- Emergency stop
- Powerful motor
- KD manufactured load chain

### I STANDARD SPECIFICATION

Model	Capacity (ton)	Lift (m)	Duty rating (min)		Lifting Speed (m/min)				Traversing Speed (m/min)		Load Chain Dia. (mm)	No. of Falls of Load Chain	Test Load (kg)
			Single	Dual	Single		Dual		50Hz	60Hz			
					50Hz	60Hz	50Hz	60Hz					
KD-2	7.5	4	30	5/15	3.0	3.6	3.0/0.8	3.6/0.9	-	-	φ11.2	4	9,375
	10	4	30	5/15	3.0	3.6	3.0/0.8	3.6/0.9	-	-	φ11.2	4	12,500
	15	4	30	5/15	1.9	2.3	1.8/0.4	2.3/0.6	-	-	φ11.2	6	18,750
	20	4	30	5/15	1.4	1.7	1.4/0.4	1.7/0.4	-	-	φ11.2	8	25,000
	25	4	30	5/15	1.1	1.3	1.1/0.3	1.3/0.3	-	-	φ11.2	10	31,250
	30	4	30	5/15	0.9	1.1	0.9/0.2	1.1/0.3	-	-	φ11.2	12	37,500
KD-2M	7.5	4	30	5/15	3.0	3.6	3.0/0.8	3.6/0.9	10	12	φ11.2	4	9,375
	10	4	30	5/15	3.0	3.6	3.0/0.8	3.6/0.9	10	12	φ11.2	4	12,500
	15	4	30	5/15	1.9	2.3	1.8/0.4	2.3/0.6	10	12	φ11.2	6	18,750
	20	4	30	5/15	1.4	1.7	1.4/0.4	1.7/0.4	10	12	φ11.2	8	25,000
	25	4	30	5/15	1.1	1.4	1.1/0.3	1.3/0.3	10	12	φ11.2	10	31,250
	30	4	30	5/15	0.9	1.1	0.9/0.2	1.1/0.3	10	12	φ11.2	12	37,500

Capacity (ton)	Output (kw)		Traversing (kw)	Net weight (kg)		Extra weight per 1m lift (kg)	
	Single	Dual		KD-2	KD-2M	KD-2	KD-2M
7.5	2 x 3.3	2 x 3.3/0.825	0.75	370(380)	460(470)	10.6	10.6
10	2 x 3.3	2 x 3.3/0.825	0.75	370(380)	460(470)	10.6	10.6
15	2 x 3.3	2 x 3.3/0.825	2 x 1.5	600(610)	760(770)	16	16
20	2 x 3.3	2 x 3.3/0.825	2 x 1.5	620(630)	780(790)	21.2	21.2
25	2 x 3.3	2 x 3.3/0.825	2 x 1.5	790(800)	980(990)	26.5	26.5
30	2 x 3.3	2 x 3.3/0.825	2 x 1.5	900(910)	1150(1160)	31.8	31.8

### I DIMENSION

Model	Capacity (ton)	Dimension (mm)										Std. Beam Width (mm)	Min. Radius for Curve (mm)
		A	B	C	D	E	F	H	S	P	G		
KD-2	7.5	770	1,220	710 (795)	-	-	-	-	-	1,300	1,440	-	-
	10	770	1,220	710 (795)	-	-	-	-	-	1,300	1,440	-	-
	15	1,000	1,530	710 (795)	-	-	-	-	-	1,725	2,000	-	-
	20	1,080	1,530	767 (855)	-	-	-	-	-	2,100	2,200	-	-
	25	1,100	1,580	924 (1004)	-	-	-	-	-	2,300	2,300	-	-
	30	1,100	1,600	870 (878)	-	-	-	-	-	2,300	2,300	-	-
KD-2M	7.5	770	1,220	175	457	289	710 (795)	158	405	940	1,140	150, 175, 190	2,500
	10	770	1,220	175	457	289	710 (795)	158	405	940	1,140	150, 175, 190	2,500
	15	1,000	1,530	175	514	355	710 (795)	180	845	1,300	1,600	150, 175, 190	-
	20	1,100	1,530	175	514	355	767 (855)	160	840	1,400	1,600	150, 175, 190	-
	25	1,100	1,580	175	514	355	924 (1004)	165	980	1,940	1,780	150, 175, 190	-
	30	1,100	1,580	175	514	355	870 (878)	165	1,070	1,940	1,780	150, 175, 190	-

( ) Dual speed Dimension Specification

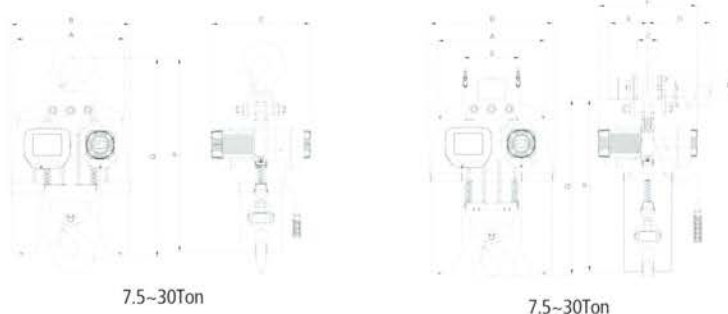

• The design, material and specification are subject to change for improvement without notice.  
 • A special specification is available upon request.  
 • 국풍호이스트(주) 제품의 규격은 품질개선을 위하여 예고없이 변경될 수 있으므로 제품 구입시 문의바랍니다.

# LOW HEAD type

Available from 0.49Ton to 5Ton capacity



## LOW HEAD type

- Hoist classification : FEM(1Bm) / ISO(M3)
- Motor & brake class : "F" class
- Ambient temperature : -20°C ~ +40°C
- Intermittent Rating(%ED) :  
single speed(25%ED) dual speed(20%ED)

- Minimized distance between hooks  
: Lower 100mm, 300mm, 700mm than standard type  
: When the building with low ceiling  
: When extended lifting height is required
- Emergency stop
- Powerful motor
- KD manufactured load chain

### I STANDARD SPECIFICATION

Model	Capacity (ton)	Lift (m)	Duty rating (min)		Lifting Speed (m/min)				Traversing Speed (m/min)		Load Chain Dia. (mm)	No. of Falls of Load Chain	Test Load (kg)
			Single	Dual	Single		Dual		50Hz	60Hz			
					50Hz	60Hz	50Hz	60Hz					
KDL-1M	0.49	4	30	5/15	6.7	8	6.7/1.7	8.0/2.0	10 (20)	12 (24)	φ7.1	1	613
	0.5	4	30	5/15	6.7	8	6.7/1.7	8.0/2.0	10 (20)	12 (24)	φ7.1	1	625
	1	4	30	5/15	6.7	8	6.7/1.7	8.0/2.0	10 (20)	12 (24)	φ7.1	1	1,250
	2	4	30	5/15	3.4	4	3.4/0.9	4.0/1.0	10 (20)	12 (24)	φ7.1	2	2,500
KDL-2M	2	4	30	5/15	6.8	8.2	6.8/1.7	8.2/2.0	10	12	φ11.2	1	2,500
	2.8	4	30	5/15	5.9	7	5.9/1.5	7/1.8	10	12	φ11.2	1	3,500
	3	4	30	5/15	5.9	7	5.9/1.5	7/1.8	10	12	φ11.2	1	3,750
KDSL-2M	5	4	30	5/15	3.0	3.6	3/0.8	3.6/0.9	10	12	φ11.2	2	6,250

Capacity (kg)	Output (kw)		Traversing (kw)	Net weight (kg)			Extra weight per 1m lift (kg)		
	Single	Dual		KDL-1M	KDL-2M	KDSL-2M	KDL-1M	KDL-2M	KDSL-2M
0.49	0.8	0.8/0.2	0.4	132 (135)	-	-	1.1	-	-
0.5	0.8	0.8/0.2	0.4	132 (135)	-	-	1.1	-	-
1	1.5	1.5/0.38	0.4	132 (135)	-	-	1.1	-	-
2	1.5	1.5/0.38	0.4	150 (153)	-	-	2.1	-	-
2	3.3	3.3/0.825	0.4	-	205 (215)	-	-	2.7	-
2.8	3.3	3.3/0.825	0.4	-	240 (250)	-	-	2.7	-
3	3.3	3.3/0.825	0.4	-	240 (250)	-	-	2.7	-
5	3.3	3.3/0.825	0.4	-	290 (300)	360 (370)	-	5.3	5.3

### I DIMENSION

Model	Capacity (ton)	Dimension (mm)										Std.I-Beam Width (mm)	Min. Radius of Curve (mm)
		A	B	C	D	E	H	S	W	P	G		
KDL-1M	0.49	258	265 (315)	75	348	213	121	230	560	663	330	75, 100, 125	-
	0.5	258	265 (315)	75	348	213	121	230	560	663	330	75, 100, 125	-
	1	258	308 (335)	100	360	225	121	230	560	663	330	75, 100, 125	-
	2	258	308 (335)	125	418	245	121	296	626	800	550	100, 125, 150	-
KDL-2M	2	307	355 (392)	125	357	245	123	296	663	900	530	100, 125, 150	-
	2.8	307	355 (392)	125	366	254	136	337	710	890	550	100, 125, 150	-
	3	307	355 (392)	125	366	254	136	337	710	890	550	100, 125, 150	-
KDSL-2M	5	307	355 (392)	125	383	271	158	384	790	1,000	760	125, 150, 175	-
KDSL-2M	5	1,050	547 (587)	150	565	-	230	-	-	745	315	125, 150, 175	-

( ) Dual speed Dimension, Specification

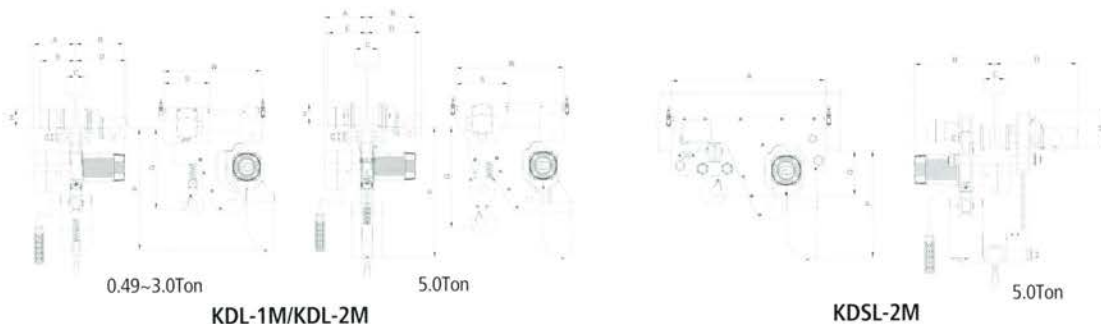

• The design, material and specification are subject to change for improvement without notice.  
 • A special specification is available upon request.  
 • 극동하이스트(주) 제품의 규격은 품질개선을 위하여 예고없이 변경될 수 있으므로 제품 구입시 문의바랍니다.

# TWIN HOOK type

Available from 0.49Ton to 5Ton capacity



## TWIN HOOK type

- Hoist classification : FEM(1Bm) / ISO(M3)
- Motor & brake class : "F" class
- Ambient temperature :  $-20^{\circ}\text{C} \sim +40^{\circ}\text{C}$
- Intermittent Rating(%ED) :  
single speed(25%ED) / dual speed(20%ED)
- Stable and balanced design & Useful service : When large and long load transports stable and safely
- Accurate level/simultaneous lifting is required : When accurate level/simultaneous lifting is required
- Emergency stop
- Powerful motor
- KD manufactured load chain



### I STANDARD SPECIFICATION

Model	Capacity (ton)	Lift (m)	Duty rating (min)		Lifting Speed (m/min)				Traversing Speed (m/min)		Load Chain Dia. (mm)	No. of Falls of Load Chain	Test Load (kg)
			Single	Dual	Single		Dual		50Hz	60Hz			
					50Hz	60Hz	50Hz	60Hz					
KEW-90 (ECW-3M)	0.245+0.245	4	30	5/15	8.3	10	8.3/2.0	10/2.5	-	-	φ6.3	1 x 2	306+307
	0.25+0.25	4	30	5/15	8.3	10	8.3/2.0	10/2.5	-	-	φ6.3	1 x 2	312+313
	0.5+0.5	4	30	5/15	5.4	6.4	5.4/1.4	6.4/1.6	-	-	φ7.1	1 x 2	625+625
	1+1	4	30	5/15	2.7	3.2	2.7/0.7	3.2/0.8	-	-	φ7.1	2 x 2	1,250+1,250
KEW-90M (EMT-ECW-3M)	0.245+0.245	4	30	5/15	8.3	10	6.7/1.7	10/2.5	10 (20)	12 (24)	φ6.3	1 x 2	306+307
	0.25+0.25	4	30	5/15	8.3	10	6.7/1.7	10/2.5	10 (20)	12 (24)	φ6.3	1 x 2	312+313
	0.5+0.5	4	30	5/15	5.4	6.4	6.7/1.7	6.4/1.6	10 (20)	12 (24)	φ7.1	1 x 2	625+625
	1+1	4	30	5/15	2.7	3.2	3.4/0.9	3.2/0.8	10 (20)	12 (24)	φ7.1	2 x 2	1,250+1,250
KDW-1	0.245+0.245	4	30	5/15	7	8	6.7/1.7	8/2	-	-	φ7.1	1 x 2	306+307
	0.25+0.25	4	30	5/15	7	8	6.7/1.7	8/2	-	-	φ7.1	1 x 2	312+313
	0.5+0.5	4	30	5/15	7	8	6.7/1.7	8/2	-	-	φ7.1	1 x 2	625+625
	1+1	4	30	5/15	3.4	4	3.4/0.9	4/1	-	-	φ7.1	2 x 2	1,250+1,250
KDW-1M	0.245+0.245	4	30	5/15	7	8	6.7/1.7	8/2	10 (20)	12 (24)	φ7.1	1 x 2	306+307
	0.25+0.25	4	30	5/15	7	8	6.7/1.7	8/2	10 (20)	12 (24)	φ7.1	1 x 2	312+313
	0.5+0.5	4	30	5/15	7	8	6.7/1.7	8/2	10 (20)	12 (24)	φ7.1	1 x 2	625+625
	1+1	4	30	5/15	3.4	4	3.4/0.9	4/1	10 (20)	12 (24)	φ7.1	2 x 2	1,250+1,250
KDW-2	1+1	4	30	5/15	6.8	8.2	6.8/1.7	8.2/2	-	-	φ11.2	1 x 2	1,250+1,250
	1.4+1.4	4	30	5/15	4.3	5.2	4.3/1.1	5.2/1.3	-	-	φ9.5	2 x 2	1,750+1,750
	1.5+1.5	4	30	5/15	4.3	5.2	4.3/1.1	5.2/1.3	-	-	φ9.5	2 x 2	1,875+1,875
	2.5+2.5	4	30	5/15	3.0	3.6	3/0.8	3.6/0.9	-	-	φ11.2	2 x 2	3,125+3,125
KDW-2M	1+1	4	30	5/15	6.8	8.2	6.8/1.7	8.2/2	10	12	φ11.2	1 x 2	1,250+1,250
	1.4+1.4	4	30	5/15	4.3	5.2	4.3/1.1	5.2/1.3	10	12	φ9.5	2 x 2	1,750+1,750
	1.5+1.5	4	30	5/15	4.3	5.2	4.3/1.1	5.2/1.3	10	12	φ9.5	2 x 2	1,875+1,875
	2.5+2.5	4	30	5/15	3.0	3.6	3/0.8	3.6/0.9	10	12	φ11.2	2 x 2	3,125+3,125

Capacity (kg)	Output (kw) (KDW)		Output (kw) (ECW)		Traversing (kw) (KDW)		Traversing (kw) (KEW (ECW))		Extra weight per 1m lift (kg)	
	Single	Dual	Single	Dual	(kw) (KDW)	(kw) (KEW (ECW))	KEW-90(ECW-3M)	KDW-1	KDW-2	
0.245+0.245	0.8	0.8/0.2	1.1	1.1/0.28	2 x 0.4	2 x 0.2	1.7	2.1	-	
0.25+0.25	0.8	0.8/0.2	1.1	1.1/0.28	2 x 0.4	2 x 0.2	1.7	2.1	-	
0.5+0.5	1.5	1.5/0.38	1.3	1.3/0.32	2 x 0.4	2 x 0.4	2.1	2.1	-	
1+1	1.5	1.5/0.38	1.3	1.3/0.32	2 x 0.4	2 x 0.4	4.2	4.2	-	
1+1	3.3	3.3/0.825	-	-	2 x 0.4	-	-	-	5.3	
1.4+1.4	3.3	3.3/0.825	-	-	2 x 0.4	-	-	-	7.9	
1.5+1.5	3.3	3.3/0.825	-	-	2 x 0.4	-	-	-	7.9	
2.5+2.5	3.3	3.3/0.825	-	-	2 x 0.4	-	-	-	10.6	

### I DIMENSION

Model	Capacity (ton)	Dimension (mm)										Std. I-Beam Width (mm)	Min. Radius of Curve (mm)
		A	B	C	D	E	P	S	W	G	H		
KEW-90 (ECW-3M)	0.245+0.245	308	322 (324)	76	-	-	800	-	1,000	675	-	-	-
	0.25+0.25	308	322 (324)	76	-	-	800	-	1,000	675	-	-	-
	0.5+0.5	308	322 (324)	76	-	-	800	-	1,000	680	-	-	-
	1+1	308	322 (324)	76	-	-	900	-	1,000	708	-	-	-
KEW-90M (EMT-ECW-3M)	0.245+0.245	308	322 (324)	75	323	228	750	240	1,000	695	110	75, 100, 125	-
	0.25+0.25	308	322 (324)	75	323	228	750	240	1,000	695	110	75, 100, 125	-
	0.5+0.5	308	322 (324)	100	335	240	750	240	1,000	705	110	75, 100, 125	-
	1+1	308	322 (324)	100	335	240	820	240	1,000	785	110	100, 125, 150	-
KDW-1	0.245+0.245	295	310	69	-	-	650	-	1,000	785	-	-	-
	0.25+0.25	295	310	69	-	-	650	-	1,000	785	-	-	-
	0.5+0.5	295	350	69	-	-	650	-	1,000	785	-	-	-
	1+1	295	350	69	-	-	650	-	1,000	860	-	-	-
KDW-1M	0.245+0.245	295	310	75	338	218	800	230	1,000	760	121	75, 100, 125	-
	0.25+0.25	295	310	75	338	218	800	230	1,000	760	121	75, 100, 125	-
	0.5+0.5	295	350	100	350	230	800	230	1,000	760	121	75, 100, 125	-
	1+1	295	350	125	363	243	800	230	1,000	895	121	100, 125, 150	-
KDW-2	1+1	352	397 (402)	90	-	-	1,100	-	1,000	760	-	-	-
	1.4+1.4	352	397 (402)	90	-	-	1,100	-	1,000	1,150	-	-	-
	1.5+1.5	352	397 (402)	90	-	-	1,100	-	1,000	1,150	-	-	-
	2.5+2.5	352	397 (402)	90	-	-	1,100	-	1,000	910	-	-	-
KDW-2M	1+1	352	397 (402)	100	416	233	1,020	296	1,000	850	123	100, 125, 150	-
	1.4+1.4	352	397 (402)	125	418	245	1,020	296	1,000	1,050	123	100, 125, 150	-
	1.5+1.5	352	397 (402)	125	418	245	1,020	296	1,000	1,050	123	100, 125, 150	-
	2.5+2.5	352	397 (402)	150	418	245	1,020	296	1,000	1,150	136	125, 150, 175	-

( ) Dual speed Dimension, Specification

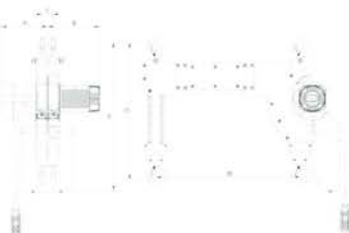

KEW-90 (ECW-3M)  
KDW-1/KDW-2

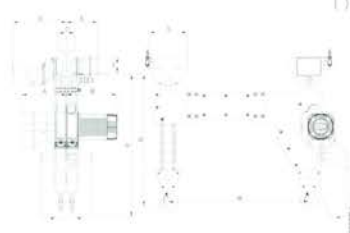

KEW-90M (EMT-ECW-3M)  
KDW-1M/KDW-2M

\* The design, material and specification are subject to change for improvement without notice.  
\* A special specification is available upon request.  
\* 곡동호이스트(주) 제품의 규격은 품질개선을 위하여 예고없이 변경될 수 있으므로 제품 구입시 문의바랍니다.

# CHAIN BLOCK(KC-70A) type

Available from 0.5Ton to 50Ton capacity



## CHAIN BLOCK type

- High efficiency and easy operation
- Powerful anchor
- Double pawl type brake system
- KD manufactured load chain

## I DIMENSION

Model	KC-70A-0.5T	KC-70A-1T	KC-70A-1.5T	KC-70A-2T	KC-70A-3T	KC-70A-5T	
Capacity (ton)	0.5	1	1.5	2	3	5	
Standard Lift (m)	2.5	2.5	2.5	3.0	3.0	3.0	
Test Load (ton)	0.75	1.5	2.3	3.0	4.5	7.5	
Pulling Effort (kg)	24	32	33	37	35	42	
Load chain (φ × falls)	6 × 1	6 × 1	8 × 1	8 × 1	8 × 2	10 × 2	
Hand Chain (φ × mm)	5.0 × 25	5.0 × 25	5.0 × 25	5.0 × 25	5.0 × 25	5.0 × 25	
Dimension (mm)	A	131	140	161	161	161	186
	B	127	158	174	187	199	253
	G	270	317	399	414	465	636
	D	35	40	45	50	58	64
	K	30	28	36	33.5	40	50
Net Weight (kg)	10	12	19	20	27	45.5	
Extra Weight 1m Lift (kg)	0.8	0.8	1.4	1.4	2.8	4.4	

Model	KC-70A-7.5T	KC-70A-10T	KC-70A-15T	KC-70A-20T	KC-70A-30T	KC-70A-50T	
Capacity (ton)	7.5	10	15	20	30	50	
Standard Lift (m)	3.0	3.0	3.0	3.0	3.0	3.0	
Test Load (ton)	9.4	12.5	18.8	25	37.5	62.5	
Pulling Effort (kg)	35	42	2 × 42	2 × 42	2 × 42	2 × 42	
Load chain (φ × falls)	10 × 4	10 × 4	10 × 8	10 × 8	10 × 12	10 × 24	
Hand Chain (φ × mm)	5.0 × 25	5.0 × 25	5.0 × 25	5.0 × 25	5.0 × 25	5.0 × 25	
Dimension (mm)	A	207	207	215	215	350	406
	B	398	398	398	650	680	962
	G	778	798	890	890	1380	2578
	D	85	85	110	110	125	165
	K	64	64	85	85	85	130
Net Weight (kg)	66	83	160	193	268	1120	
Extra Weight 1m Lift (kg)	6.6	8.8	13.2	17.6	26.4	52.8	

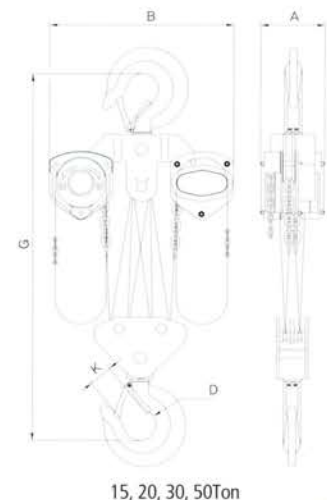
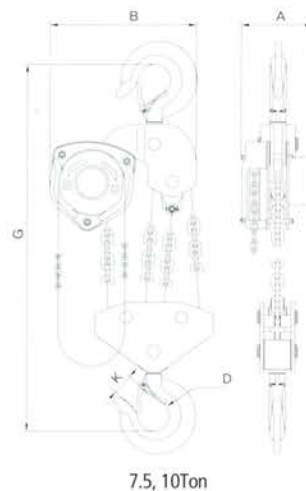
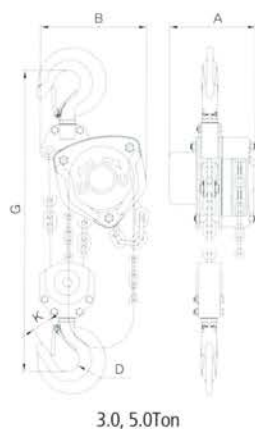
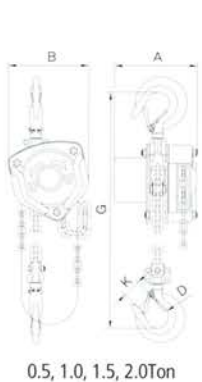

• The design, material and specification are subject to change for improvement without notice.  
 • A special specification is available upon request.  
 • 국풍로이스트(주) 제품의 규격은 품질개선을 위하여 예고없이 변경될 수 있으므로 제품 구입시 문의바랍니다.

# LEVER BLOCK(LB-90A) type

Available from 0.25Ton to 6Ton capacity



## LEVER BLOCK type

- High efficiency and easy operation by high reduction ratio
- Easy chain control by automatic brake
- KD manufactured load chain

## I DIMENSION

Model	LB-90A					
Capacity (ton)	0.25	0.5	0.75	1.5	3.0	6.0
Standard Lift (m)	1.0	1.5	1.5	1.5	1.5	1.5
Test Load (ton)	0.38	0.75	1.13	2.25	4.5	7.5
Pulling Effort (kg)	25	34	14	22	32	34
Load chain ( $\phi \times$ falls)	4 x 1	5 x 1	6 x 1	8 x 1	10 x 1	10 x 2
Dimension (mm)	A	92	105	145	175	203
	B	72	78	86	100	118
	C	85	80	122	130	150
	D	25	30	37	45	50
	G	230	260	325	380	480
	L	160	300	280	410	410
Net Weight (kg)	1.8	4.0	7.5	11.5	21	31.5
Extra Weight 1m Lift (kg)	0.4	0.5	0.8	1.4	2.2	4.4

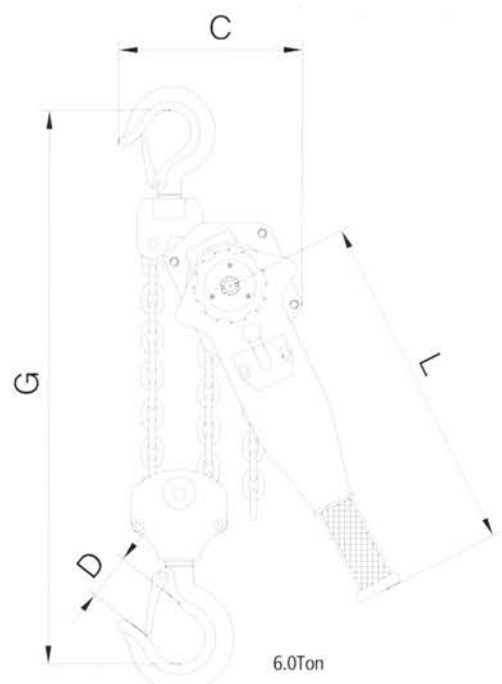
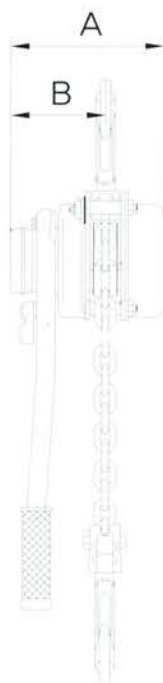
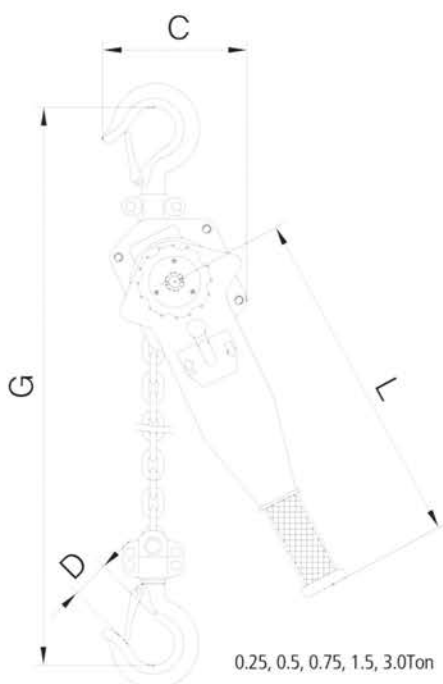

\* The design, material and specification are subject to change for improvement without notice.  
 \* A special specification is available upon request.  
 \* 국동호이스트(주) 제품의 규격은 품질개선을 위하여 예고없이 변경될 수 있으므로 제품 구입시 문의바랍니다.

# TROLLEY(KG) type

Available from 0.5Ton to 20Ton capacity



## I DIMENSION

Capacity (ton)	Min. Radius of Curve (m)	Test Load (ton)	Net Weight (kg)	I-Beam Recommended (mm)	Dimension (mm)			
					A	B	C	H
0.5	0.9	0.75	14	64~140	212	308.5	198.5	113
1	1.0	1.5	19	64~140	255	328.5	231.5	128
2	1.1	3	29	76~165	302	361.5	278	152
3	1.3	4.5	40	76~203	344	428.5	338	186
5	1.4	7.5	65	88~203	378	434	393	219
10	2.5	12.5	103	125~203	455	487.5	490	275.5
15	3.5	18.8	245	136~203	642	547	622	315
20	3.5	25	245	136~203	642	547	622	315

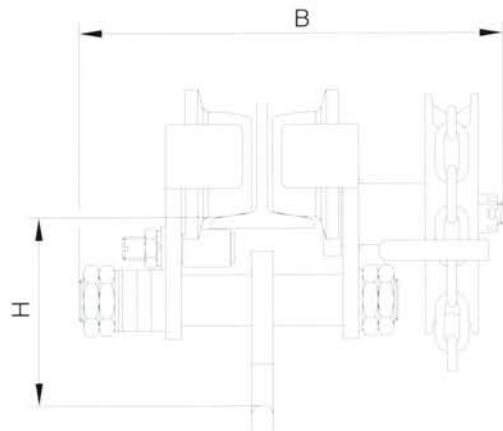
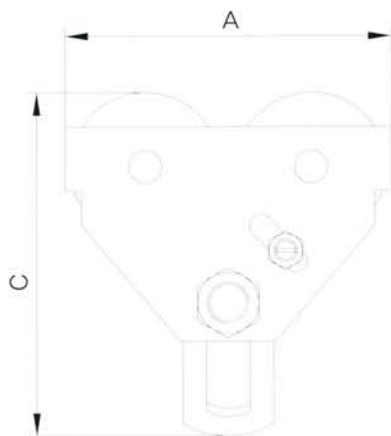

0.5Ton~20Ton

# TROLLEY(KP) type

Available from 0.5Ton to 20Ton capacity

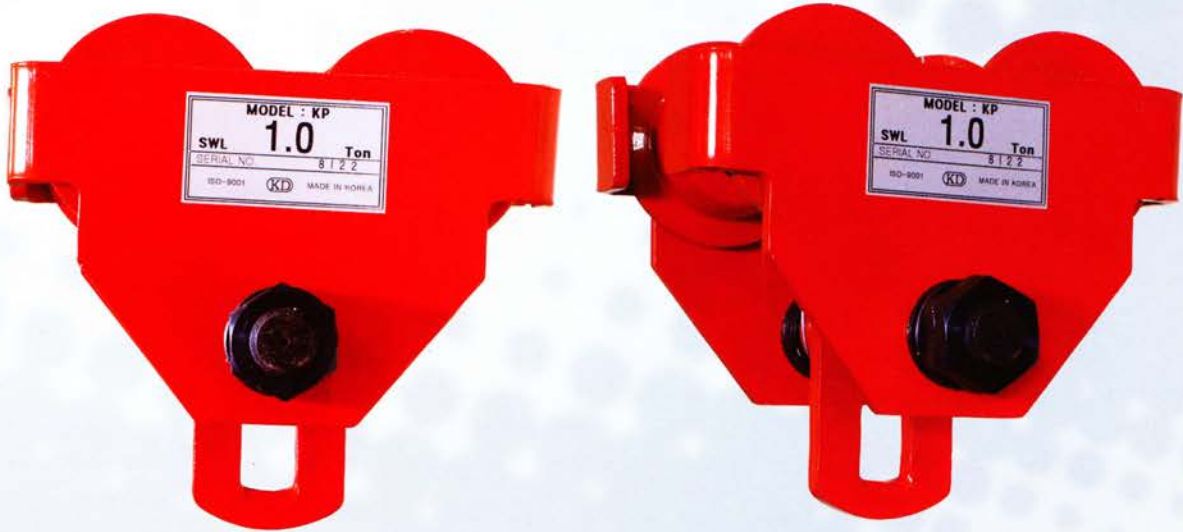

## I DIMENSION

Capacity (ton)	Min. Radius of Curve (m)	Test Load (ton)	Net Weight (kg)	I-Beam Recommended (mm)	Dimension (mm)			
					A	B	C	H
0.5	0.9	0.75	7	64~140	212	230	198.5	113
1	1.0	1.5	12	64~140	255	254	231.5	128
2	1.1	3	22	76~165	302	294	278	152
3	1.3	4.5	30	76~203	344	344	338	186
5	1.4	7.5	55	88~203	378	360	393	219
10	2.5	12.5	93	125~203	455	403	490	275.5
15	3.5	18.8	235	136~203	642	475	622	315
20	3.5	25	235	136~203	642	475	622	315

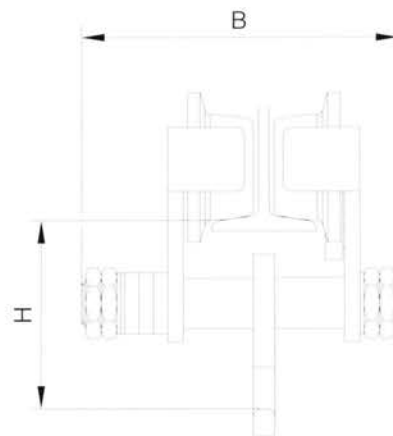
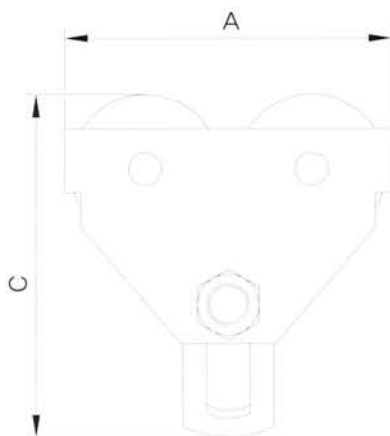

0.5Ton~20Ton

• The design, material and specification are subject to change for improvement without notice.  
 • A special specification is available upon request.  
 • 국동호아스트(주) 제품의 규격은 품질개선을 위하여 예고없이 변경될 수 있으므로 제품 구입시 문의바랍니다.

# LOAD CHAIN type

■ Diameter : 6.3mm ~ 11.2mm



■ Diameter : 6.0mm ~ 11.1mm



## KT Series

Hardened on the surface, it is great product of Grade-80 made of highly qualified alloy steel. By case hardened heat treatment, the product Surface Hardened is excellent in breaking strength and abrasion.

Passing the successive load test at each link, and strict quality control the product is precise and safe. With the precision and the prevention against abrasion and breakage, this product is used well for the case bellow.

- (1) Electric Chain Hoist
- (2) Chain Conveyor System
- (3) Parking Equipment

High quality product for the stan-dard of KS, JIS, ISO.

고품질의 합금강을 소재를 사용하여, 제작된 Grade-80의 고강력제품입니다.

가스침탄 열처리를 실시하여, 표면경화 (Surface Hardened)된 제품으로 파단강도 및 내마모성이 우수합니다.

각 링크마다 연속하중시험기를 통과하여, 전량 엄격한 품질검사를 통과한 정밀하고, 안전한 제품입니다. 뛰어난 내마모성, 파단강도 및 정밀성으로 (1) 전동 체인호이스트 (2) 체인콘베어 시스템 (3) 주차설비 등에 이용됩니다. KS, JIS, ISO 등 제 규격에 합당한 고품질의 제품입니다.

## KH Series

Quenched and tempered on the surface, it is the great product of Grade-80 made of highly qualified alloy steel and optimized with elongation by HRC 40.

For that character, it is mainly used for the below cases which have low frequency of consecutive use.

- (1) Chain Block, Lever Block
- (2) Parking Equipment

High quality product for the stan-dard of KS, JIS, ISO.

고품질의 합금강을 소재로 사용하여, 제작된 Grade-80의 고강력 제품입니다.

조질열처리 (HRC40)를 실시하여, 연신율을 최적화한 제품입니다.

제품의 특성상 연속사용 빈도수가 낮은 (1) 체인블록, 레버블록 (2) 주차설비 등에 주로 이용됩니다.

KS, JIS, ISO 등 제 규격에 합당한 고품질의 제품입니다.



### I KT Series

Item No.	Diameter (mm)	Inside Length (mm)	Outside Length (mm)	Weight (kg/m)	Safety working load (kg)	Proof load (kg)	Breaking load (kg)	Elongation (%)
KT063	6.3	19.1	20.5	0.86	1250	2500	5000	6
KT071	7.1	21.2	23.0	1.06	1600	3150	6300	6
KT079	7.9	23.0	25.5	1.38	2000	4000	8000	6
KT079	7.9	25.4	25.5	1.38	2000	4000	8000	6
KT095	9.5	28.6	31.0	1.98	3000	6000	12000	6
KT111	11.1	33.3	36.0	2.65	4000	8000	16000	6
KT112	11.2	34.0	36.0	2.70	4000	8000	16000	6
KT112	11.2	34.3	36.0	2.70	4000	8000	16000	6

### I KH Series

Item No.	Diameter (mm)	Inside Length (mm)	Outside Length (mm)	Weight (kg/m)	Safety working load (kg)	Proof load (kg)	Breaking load (kg)	Elongation (%)
KH060	6.0	18.0	21.6	0.80	1000	2500	4000	15
KH071	7.1	20.2	23.0	1.06	1600	3150	6300	15
KH079	7.9	23.0	25.5	1.38	2000	4000	8000	15
KH080	8.0	24.0	26.0	1.40	2000	4000	8000	15
KH090	9.0	27.0	30.0	1.87	2500	5000	10000	15
KH095	9.5	28.6	31.0	1.98	3000	6000	12000	15
KH100	10.0	30.0	33.2	2.20	3150	6300	12500	15
KH100	10.0	35.0	34.8	2.20	3150	6300	12500	15
KH111	11.1	33.3	36.0	2.65	4000	8000	16000	15

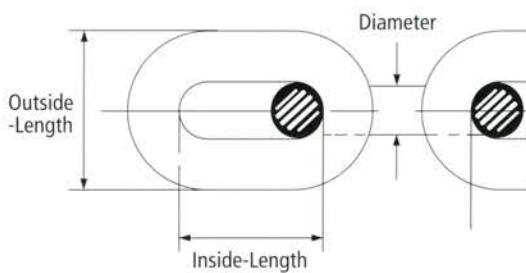

Item No.	KT series	KH series
Materials (재 질)	Alloy steel	Alloy steel
Hardness (경 도)	HV600	HRC40
Finish (표면처리)	Black or Bright	Black or Bright
Elongation (연 신 율)	6%	15%
SafetyFactor (안 전 율)	5	5

### I Load Chain Notable (Load Chain 사용시 주의사항)

1. Prevent the chain from the tangle.
  2. Do not exceed the safe load.
  3. Do not shock.
  4. Keep from rust.
  5. Carry out the periodical Pitch inspection, replace it with new one if there is a modification of the Load Chain.
1. 체인이 꼬이지 않도록 주의할 것.
  2. 안전사용 하중을 초과하지 말 것.
  3. 충격을 주지 말 것.
  4. 부식으로부터 보호할 것.
  5. 정기적인 Pitch검사를 실시하여, Load Chain의 변형이 발견되었을 경우, 즉시 교환할 것.

• The design, material and specification are subject to change for improvement without notice.  
 • Special specification is available upon request.  
 • 국동호아스티(주) 제품의 규격은 품질개선을 위하여 예고없이 변경될 수 있으므로 제품 구입시 문의바랍니다.

# CHAIN SLING type

## ■ KS Series (Tie Down Chain)



Sling Chain is much lighter and stronger than general chain. Being Superior to Steel Wire Rope in safety and flexibility, it is more convenient to work.

It can guarantee 100% safe load even the  $-40^{\circ}\text{C} \sim 200^{\circ}\text{C}$ , Highly qualified product for the standard of KS, ISO, JIS.

일반체인에 비해 경량이며, 고강도입니다.

안전도가 Steel Wire rope보다 훨씬 뛰어납니다.

유연성이 좋아 작업이 편리합니다.

$-40^{\circ}\text{C} \sim 200^{\circ}\text{C}$  에서도 100%의 안전사용하중을 견딜 수 있습니다.

KS, ISO, JIS등 제 규격에 합당한 고품질의 제품입니다.

Tie down Chain	Length	Diameter × Pitch	Hardness	Elongation
7mm (9/32")	2.8mm	7.1mm × 22.0	HRC40	15%
8mm (5/16")	2.8mm	7.9mm × 23.0	HRC40	15%
8mm (5/16")	2.8mm	7.9mm × 25.4	HRC40	15%
10mm (3/8")	6.0mm	10.0mm × 30.0	HRC40	15%



1. Single Sling    2. Double Sling    3. Triple Sling    4. Quaruple Sling    5. Basket Sling

# WEB SLING type

## ■ Round Sling

The Label gives more detailed information concerning the load capacity of the sling at different lifting angles. 라벨에는 여러 인양각도에 따라 변화하는 인양능력에 대한 설명이 있습니다.

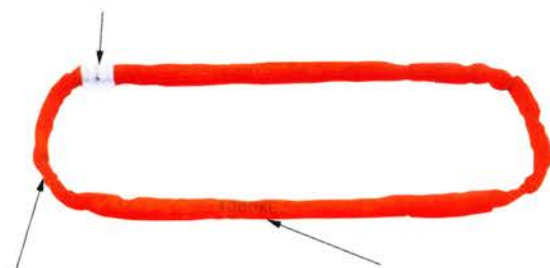

The woven stripes show the working load limited(WLL) be tons. 직조된 선이 작업한계 톤 수의 숫자를 의미합니다.

The KG Mark on the round slings shows the possible load in a straight lifting. 스탬프로 찍혀있는 KG표시는 직선으로 인양할때 허용되는 무게입니다.

## ■ Web Sling

Form A type : web-sling with eye & eye type (양쪽끝이 고리형태로 된 web-sling)

The eyes are strengthened with polyester cover, witch makes the friction between the sling and the hook to be reduced. (고리는 폴리에스터 덮개로 보강 되어서, sling 과 hook 사이의 마찰을 감소시키고 보호합니다.)



A label is woven into each sling from which the allowed direct lift load in KG and the effect of various angles on lifting capacity can be seen.

(Sling에는 라벨이 부착되어 있으며, 직선 인양시의 KG 또는 여러 각도 인양시의 KG가 표시되어 있습니다.)

Form B type : Endless web sling (원형의 web-sling)

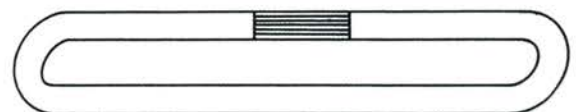

Effective Length  
Circumference = 2 × Effective Length (직선길이 × 2 = 전체둘레의 길이)



▲ HAND PALLET



▲ KCGL-70A



▲ WIRE ROPE WINCH

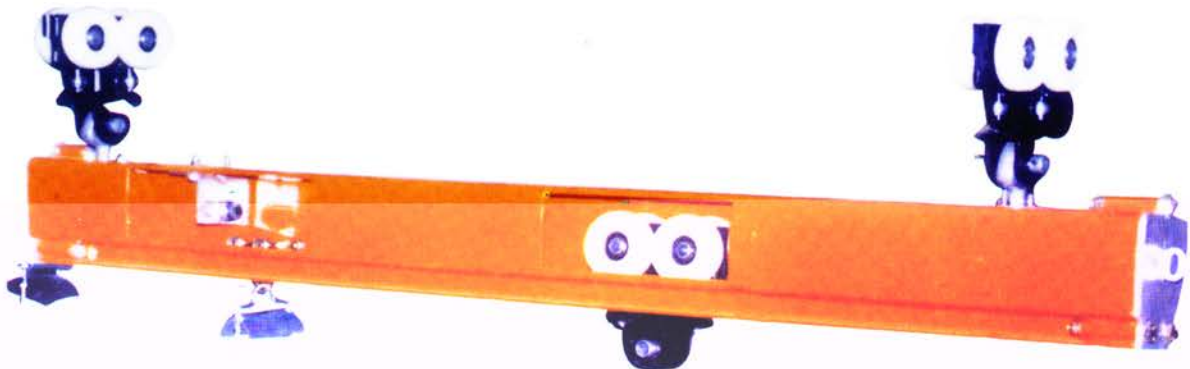

▲ LIGHT RAIL SYSTEM

MATERIAL HANDLING EQUIPMENT  
**KUKDONG**



บริษัท ไทแทน เซอร์วิส จำกัด

1/19 หมู่ 1 ต.พิมพา อ.บางปะกง จังหวัด ฉะเชิงเทรา 24180 ประเทศไทย TAX ID 0245554000604 TEL.038-989-373

ถึง 76 FAX.038-989-377 LINE : @titanservice Email : info.titanservice@gmail.com

www.titanservice.co.th Facebook.com/Titanservicecompany



**Head Office & Factory**

630-2, Sunggok-dong, Danwon-Gu, Ansan-city, Kyunggi-do, KOREA

T. 82-31-491-5311 F. 82-31-492-0473

E-mail : kukdong@kdhoist.com

**Overseas DEPT.**

T. 82-2-783-4203 F. 82-2-784-6340

E-mail : kukdong@kita.net

**A/S Office**

080-380-0001

**Home-page**

<http://www.kdhoist.com>